

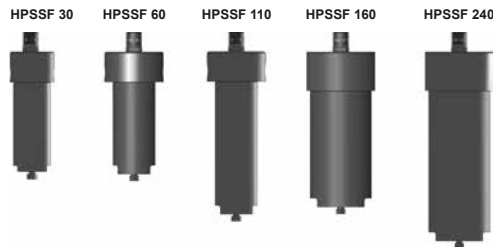

## Inline Filter HPSSF

up to 130 l/min, up to 700 bar



### 1. TECHNICAL SPECIFICATIONS

#### 1.1 FILTER HOUSING

##### Construction

The filter housings are designed in accordance with international regulations. They consist of a filter head and a screw-on filter bowl.

Standard equipment:

- bypass valve
- connection for a clogging indicator
- oil drain plug in filter bowl

#### 1.2 FILTER ELEMENTS

HYDAC filter elements are validated and their quality is constantly monitored according to the following standards:

- ISO 2941
- ISO 2942
- ISO 2943
- ISO 3724
- ISO 3968
- ISO 11170
- ISO 16889

Filter elements are available with the following pressure stability values:

Betamicon® (BN4HC):	20 bar
Betamicon® (BN4HC) /-SS-SO361:	20 bar
Betamicon® (BH4HC):	210 bar
Betamicon® (BH4HC) /-SS-SO361:	210 bar
Stainless steel wire mesh (D):	210 bar
Wire mesh (W/HC):	20 bar
Chemicon® (M):	210 bar

#### 1.3 FILTER SPECIFICATIONS

Nominal pressure	600 bar (with BSP thread) 700 bar (with NPT(F) thread or Autoclave)
Test pressure	990 (Design pressure 660 bar) or 1137.5 bar (Design pressure 770 bar)
Temperature range	-20 °C to +100 °C
Material of filter head	316S11 EN 1.4404 stainless steel
Material of filter bowl	UNS S31803 DUPLEX EN 1.4462
Type of clogging indicator	VDHP (Diff. pressure indicator up to 700 bar operating pressure)
Pressure setting of clogging indicator	5 bar (others on request)
Bypass cracking pressure	6 bar (others on request)

#### 1.4 SEALS

FPM (Viton)

#### 1.5 INSTALLATION

Inline filter

#### 1.6 SPECIAL MODELS AND ACCESSORIES

- Seals in NBR, NLT, EPDM, HNBR, Kalrez®
- Without bypass valve
- Without port (no clogging indicator)
- With visual/electrical clogging indicator
- With gauge ports (for external piping of pressure sensors)
- Reverse flow check
- Twin indicator version
- Ex or IS differential pressure indicators
- Flanged versions available (SAE, RF, RTJ, Destec®)

#### 1.7 SPARE PARTS

See Original Spare Parts List

#### 1.8 CERTIFICATES AND APPROVALS

On request

#### 1.9 COMPATIBILITY WITH HYDRAULIC FLUIDS ISO 2943

- Hydraulic oils H to HLPD DIN 51524
- Lubrication oils DIN 51517, API, ACEA, DIN 51515, ISO 6743
- Compressor oils DIN 51506
- Biodegradable operating fluids VDMA 24568 HETG, HEES, HEPG
- Fire-resistant fluids HFA, HFB, HFC and HFD
- Operating fluids with high water content (> 50 % water content) on request

#### Symbol for hydraulic systems

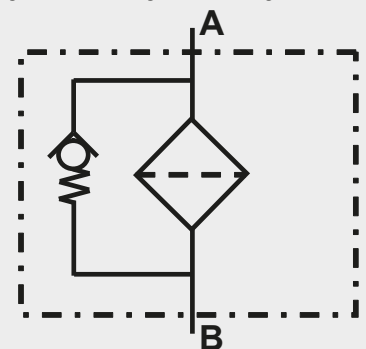

## 2. MODEL CODE (also order example)

### 2.1 COMPLETE FILTER

HPSSF600 BH/HC 60 N2 005 B X /-V

#### Filter type

HPSSF600 600 bar (BSP thread)  
 HPSSF700 700 bar (NPT/Autoclave thread)

#### Filter material of element

BN/HC Betamicon® (BN4HC)  
 BH/HC Betamicon® (BH4HC)  
 "SS-SO361" must be used for water-glycol applications!  
 M Chemicron®  
 WHC Wire mesh  
 D Stainless steel wire mesh

#### Size of filter

30, 60, 110, 160, 240

#### Type and size of connection for HPSSF600

Type	Port thread	Filter size				
		30	60	110	160	240
B0	1/4" BSPP	●				
B2	1/2" BSPP	●	●	●	●	●
B3	3/4" BSPP		●	●	●	●
B4	1" BSPP				●	●

#### Type and size of connection for HPSSF700

Type	Port thread	Filter size				
		30	60	110	160	240
N0	1/4" NPT	●	●			
N2	1/2" NPT	●	●	●	●	●
N3	3/4" NPT		●	●	●	●
N4	1" NPT				●	●
AA	7/16"-20 SF 250 CX20 - 1/4" TUBE O.D.	●				
A0	9/16"-18 SF 375 CX20 - 3/8" TUBE O.D.	●	●	●		
A1	13/16"-16 SF 562 CX20 - 9/16" TUBE O.D.		●	●	●	●
A2	3/4"-14z SF 750 CX20 - 3/4" TUBE O.D.				●	●
A3	1-3/8"-12 SF 1000 CX20 - 1" TUBE O.D.				●	●

#### Filtration rating in µm

BN/HC, BH/HC : 003, 005, 010, 020  
 BN/HC, BH/HC (-SS-SO361) : 003, 010  
 M : 001, 003, 005, 010, 020  
 W/HC : 025, 050, 100, 200  
 D : 025, 040, 060, 100, 150, 200, 250

#### Type of clogging indicator

W without port (no clogging indicator)  
 A stainless steel blanking plug in indicator port  
 B visual  
 BM visual with manual reset  
 C electrical  
 D visual and electrical  
 BM+C visual with manual reset + electrical (= 2 indicators) - not for size 30  
 E 1/4"-NPT gauge ports for external connection of pressure sensors – not for size 30

For other clogging indicators see brochure no. 7.050../..

#### Modification number

X the latest version is always supplied

#### Supplementary details

B. cracking pressure of bypass valve (e.g. B6 = 6 bar); no details = without bypass valve  
 EX electrical clogging indicator EX version (Eexd IIC T6; cable length 0.25 m standard)  
 EX/ENC electrical clogging indicator EX version (Eexd IIC T6; with IP66 junction box, M20x1.5 cable entry)  
 IS intrinsically safe electrical clogging indicator with cable length 0.25 m (standard)  
 IS/ENC intrinsically safe electrical clogging indicator with IP66 junction box (M20x1.5 cable entry)  
 L... light with appropriate voltage (24, 48, 110, 220 Volt) ] only for clogging indicators  
 LED 2 light-emitting diodes up to 24 Volt ] type "D"  
 RC with reverse flow check (not for size 30)  
 TB6 with triple bypass for reversible flow (= 1 check valve, 2 bypass valves - not for size 30)  
 N NBR seals  
 V FPM seals  
 NLT nitrile low temperature seals  
 HNBR hydrogenated nitrile (high temperature) seals  
 EPDM EPDM seals  
 K Kalrez® seals  
 SS-SO361 stainl. steel core and end caps, polyamide support fibre, optimised for water-glycol

## 2.2 REPLACEMENT ELEMENT

**0060 D 003 BN4HC /-V-SS-SO361**

**Size**  
0030, 0060, 0110, 0160, 0240

**Type**  
D

**Filtration rating in µm**  
BN4HC, BH4HC : 003, 005, 010, 020  
(Note: for /-SS-SO361 type  
only 003 and 010 µm)  
W/HC : 025, 050, 100, 200

**Filter material**  
BN4HC, BH4HC, W/HC

**Supplementary details**  
SS-SO361 stainl. steel core and end caps, polyamide support fibre  
N, V, NLT, HNBR, EPDM, K (for descriptions, see Point 2.1)

## 2.3 REPLACEMENT ELEMENT - PROCESS TECHNOLOGY

**060-DH-100-D-V**

**Size**  
030, 060, 110, 160, 240

**Type**  
DH

**Filtration rating in µm**  
Chemicon® (M) : 001, 003, 005, 010, 020  
Wire mesh (D) : 025, 040, 060, 100, 150, 200, 250

**Filter material**  
M, D

**Supplementary details**  
N, V, NLT, HNBR, EPDM, K (for descriptions, see Point 2.1)

## 2.4 REPLACEMENT CLOGGING INDICATOR

**VDHP 5 D . X /-V-L24**

**Type**  
VDHP differential pressure measurement  
up to 700 bar operating pressure

**Pressure setting**  
5 standard 5 bar, others on request

**Type of clogging indicator**  
(see Point 2.1)

**Modification number**  
X the latest version is always supplied

**Supplementary details**  
L..., LED, V, W (for descriptions, see Point 2.1)

### 3. FILTER CALCULATION / SIZING

The total pressure drop of a filter at a certain flow rate Q is the sum of the housing  $\Delta p$  and the element  $\Delta p$  and is calculated as follows:

$$\Delta p_{\text{total}} = \Delta p_{\text{housing}} + \Delta p_{\text{element}}$$

$$\Delta p_{\text{housing}} = (\text{see Point 3.1})$$

$$\Delta p_{\text{element}} = Q \cdot \frac{SK^*}{1000} \cdot \frac{\text{viscosity}}{30}$$

(\*see Point 3.2)

For ease of calculation, our Filter Sizing Program is available on request free of charge.

**NEW:** Sizing online at [www.hydac.com](http://www.hydac.com)

#### 3.1 $\Delta p$ -Q HOUSING CURVES BASED ON ISO 3968

The housing curves apply to mineral oil with a density of 0.86 kg/dm<sup>3</sup> and a kinematic viscosity of 30 mm<sup>2</sup>/s. In this case, the differential pressure changes proportionally to the density.

##### Size 30: 1/4" BSPP/NPT

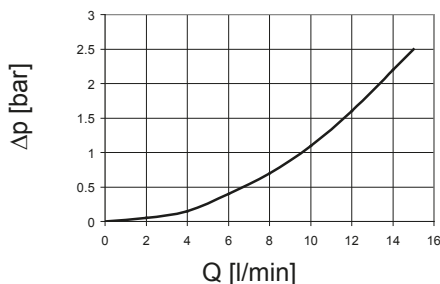

##### Size 30: 1/2" BSPP/NPT

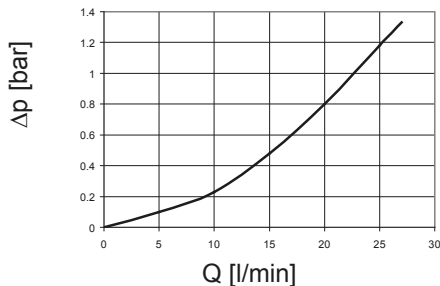

##### Size 60-110: 1/2" BSPP/NPT

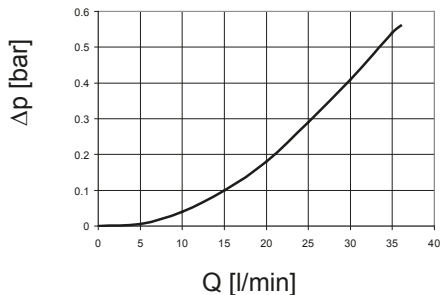

##### Size 60-110: 3/4" BSPP/NPT

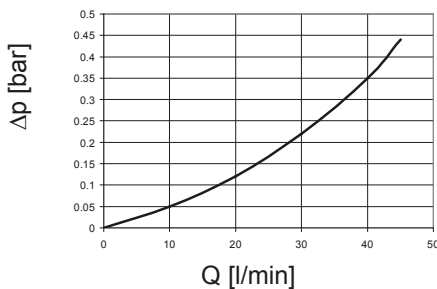

##### Size 60-240: 1" BSPP/NPT

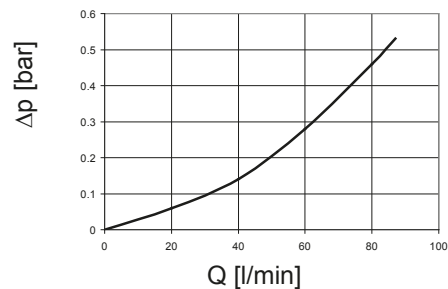

#### 3.2 GRADIENT COEFFICIENTS (SK) FOR FILTER ELEMENTS

The gradient coefficients in mbar/(l/min) apply to mineral oils with a kinematic viscosity of 30 mm<sup>2</sup>/s. The pressure drop changes proportionally to the change in viscosity.

	BH4HC		W/HC
	3 μm	10 μm	—
30	91.2	36.3	—
60	58.6	18.1	0.757
110	25.4	8.9	0.413
160	16.8	5.9	0.283
240	10.6	3.9	0.189

##### BN4HC: 30

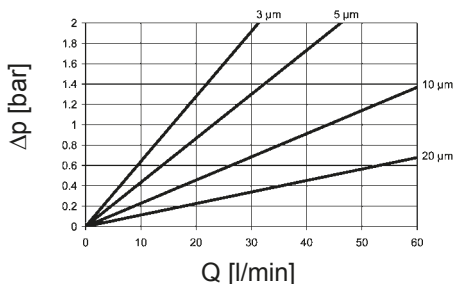

##### BN4HC: 160

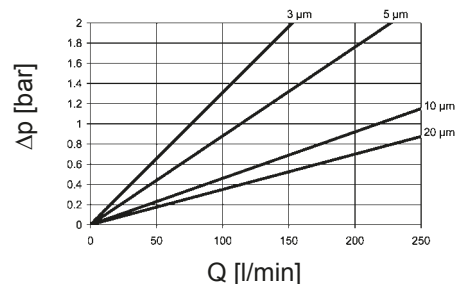

##### BN4HC: 60

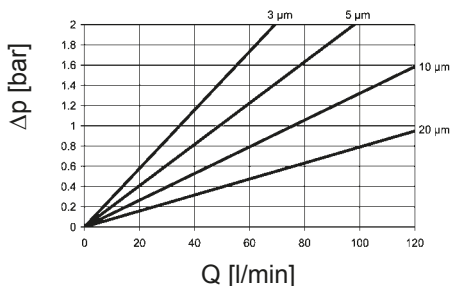

##### BN4HC: 240

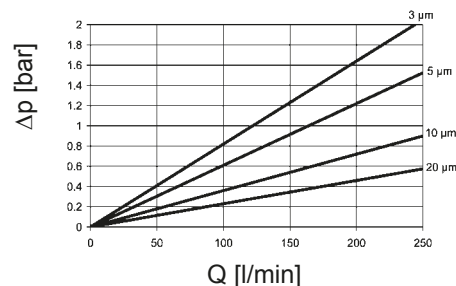

##### BN4HC: 110

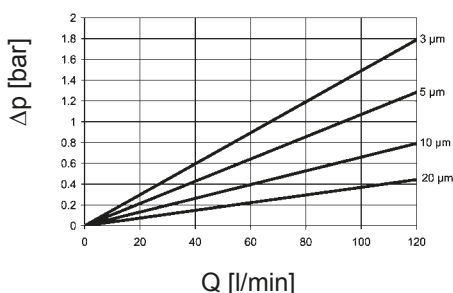

## 4. DIMENSIONS

Inline Filter HPSSF

Size 30

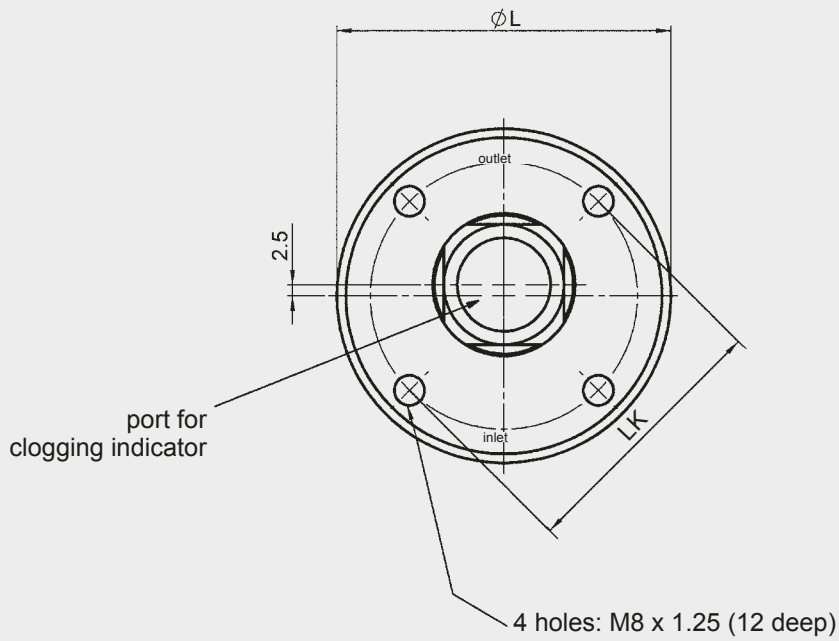
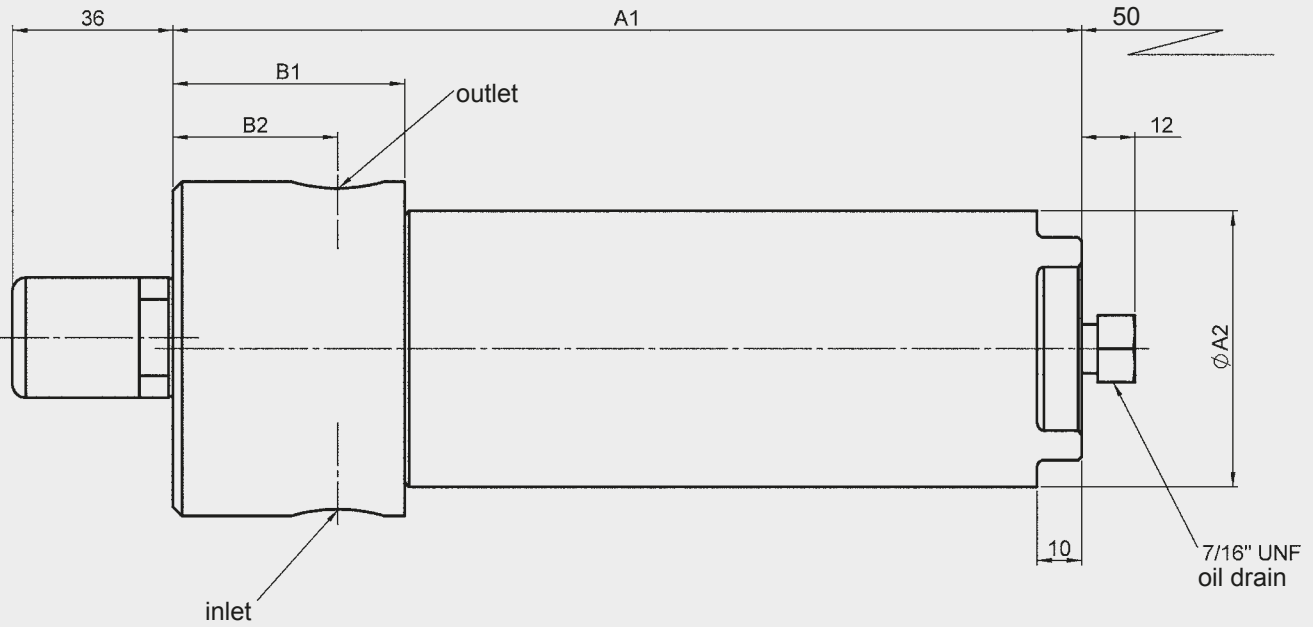

MPSSF	A1	A2	B1	B2 ±5mm	L	LK
30	204	63.5	52	37	75	60
30 (1/4" NPT)	196	63.5	44	34	66	50

Inline Filter HPSSF

Size 60 - 240

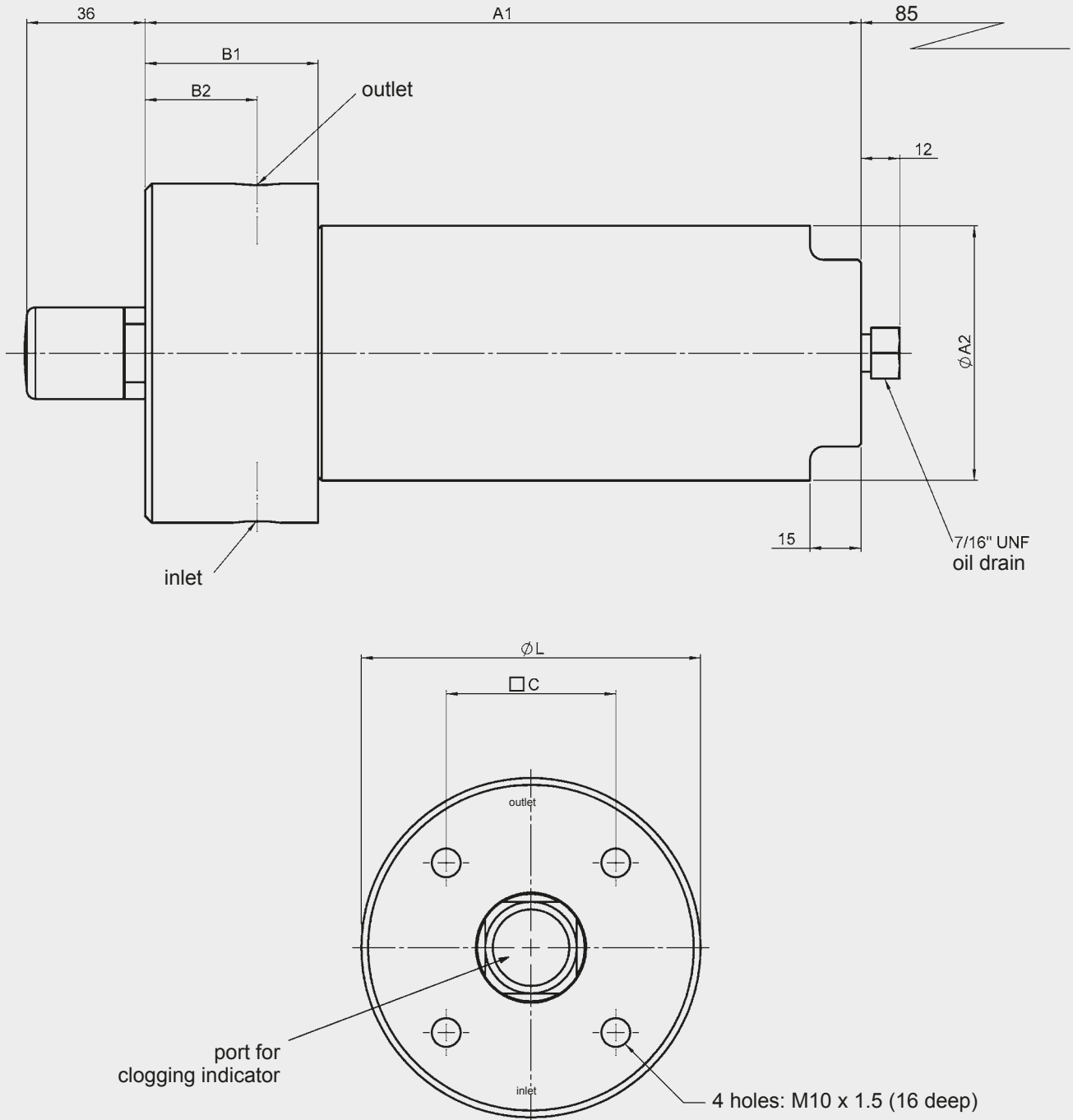

HPSSF	A1	A2	B1	B2 ±5mm	C	L	W
60	210	72	51	35	50	100	93
110	280	72	51	35	50	100	93
160	265	104	66	36	60	127	116
240	325	104	66	36	60	127	116

**NOTE**

The information in this brochure relates to the operating conditions and applications described.  
 For applications or operating conditions not described, please contact the relevant technical department.  
 Subject to technical modifications.

**HYDAC Filtrertechnik GmbH**  
 Industriegebiet  
**D-66280 Sulzbach/Saar**  
 Tel.: 0 68 97 / 509-01  
 Fax: 0 68 97 / 509-300  
 Internet: [www.hydac.com](http://www.hydac.com)  
 E-Mail: [filter@hydac.com](mailto:filter@hydac.com)